

2026 *Andante Largo*

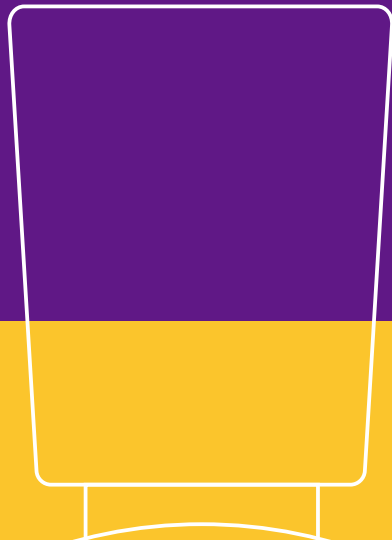

2026

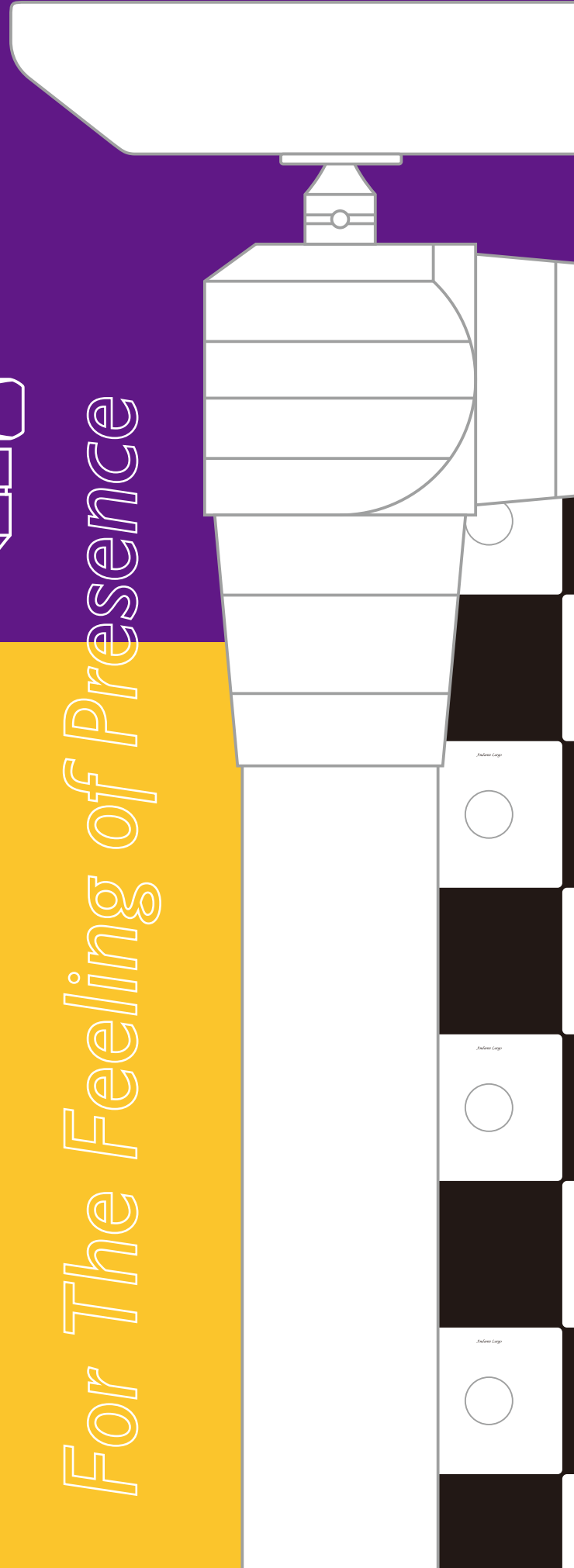
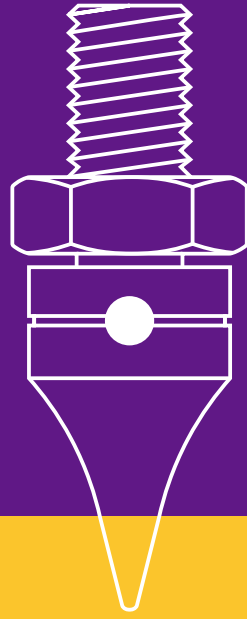

Super

接点安定剂
STMD-10

TMD

Andante Largo

For The Feeling of Presence

Contents

Category	Page	Contents
Racks	4	Technologies of Rack, Table and Board
Racks	6	Grand Series
Racks	10	Rigid Series
Spike reciever	14	Silent Mount
Spikes	18	Through-Hole Spikes
Contact enhancer fluid	20	Super TMD
User album	22	Examples of How to Use
How to listen	26	Andante Largo Standard
Infomation	30	Dimention and Options

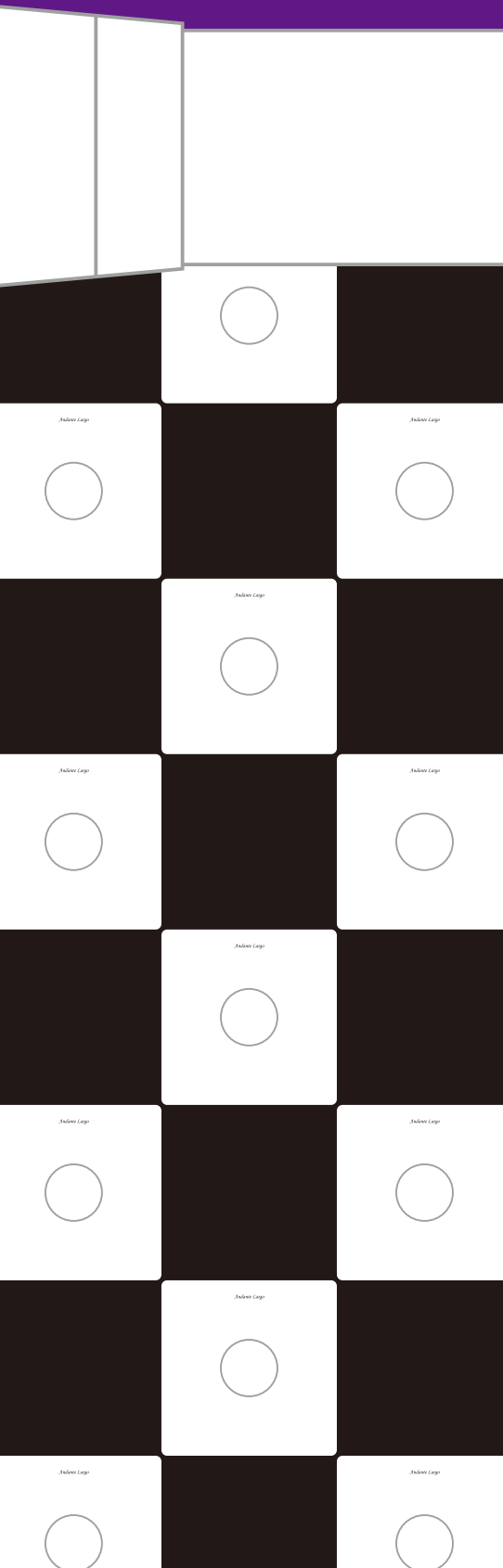

Grand Series



Rigid Series



Weefolk Board



Common
Design Policy

All Andante Largo racks (racks, tables, boards) are designed with the following policies.

Lightweight

Example: Extra super duralumin parts such as pipe joints / Titanium pipe / Hollow out shelf board etc.

Heavyweight racks and boards tend to be thought to be resistant to vibration (hard to vibrate), but in fact they are always vibrating due to the energy from the speakers. The weight of the rack or board, combined with the weight of the equipment on board, resonates at a lower frequency band.

And once a heavy object begins to vibrate, it will not stop immediately. This is a very big stress for precision equipment, and it adversely affects the playback sound.

The advantage of light racks and boards is that their low inertial weight makes it easier to dampen vibrations, which is a challenge in audio/visual environments. Therefore, we believe that racks should be designed to be lightweight. (For GT503 Mid, weight is 11.4kg)

- Grand Tower corner joint
(Made of Extra Super Duralumin)



Robustness

Example: Extra super duralumin parts such as pipe joints Titanium pipe / High-strength structural adhesive "3M DP-460" etc.

General modular racks have advantages such as expandability. However, it is difficult to secure a stable strength for structures that use many screws, and they tend to sway easily. Also, over long periods of use, the screws may become loose due to vibration, humidity, temperature fluctuations, etc., which can also cause vibration.

Although it overlaps a little with the item of "lightweight", vibration due to lack of strength is also a major obstacle to the operation of the equipment. **Andante Largo's racks pursue the "Essence" of audio and video accessories rather than "Ease of use" such as expandability. The material and structure are thoroughly examined, and the design is extremely high strength. Robustness and semi-permanent durability are essential for maximizing the performance of your equipment.**

- Board cutout (Standard KT shape)



Compact

Example: Simple design without decoration
Variety of sizes, etc.

If the rack is made larger than necessary, the weight will increase, it will be difficult to secure the strength, and as a result, it will become weak against vibration. **Keeping it to the minimum necessary size is a shortcut to a lightweight and robust design.** Therefore, it has a simple and compact design that eliminates waste as much as possible, and is available in a variety of sizes.

- Pipe internal view



Damping

Examples: Silicon, wool, cancel balls inside pipes hollowing out shelves, etc.

The above three items are essential for damping, but various other technologies are also incorporated. **A high level of "squeal" control is required for a lightweight and robust structure, but the increase in weight is minimized.**

GT503Mid • GS62I • GB540
(Spike mounts are sold separately)



GRAND SERIES

Overview (see next page for technical details)

Rigid series (page 10) While following the development policy of "light weight, robustness, compactness, and damping," the Grand series was born as a result of pursuing the ideal without cost constraints. The pipe joints, which determine the strength in particular, are completely new designs using Extra super duralumin.

From a wide variety of colors, sizes, number of stages, etc., we will hand - manufacture each unit with specifications that are perfect for your system. Please experience the "Ultimate rack" that we think of. (Recommended spike mounts : SM-5TX or SM-3TX)



Grand Tower (Multi-tier rack)

GT 743 Mid

○ Please refer to the dimension table at the end of this catalog for sizes and options.

① ② ③

- ① Height : 74 74 cm
- ② Tiers : 3 3 steps
- ③ Board Size : (No notation) . . 620 × 517 mm
Mid 540 × 445 mm

- GT 935 ● GT 935 Mid ● GT 684 ● GT 684 Mid
- GT 934 ● GT 934 Mid ● GT 683 ● GT 683 Mid
- GT 865 ● GT 865 Mid ● GT 553 ● GT 553 Mid
- GT 864 ● GT 864 Mid ● GT 552 ● GT 552 Mid
- GT 744 ● GT 744 Mid ● GT 503 ● GT 503 Mid
- GT 743 ● GT 743 Mid ● GT 502 ● GT 502 Mid



• GS541 + SM-5TX



Grand Solo (Table for players)

GS 542

◎ All heights are 445mm
○ Please refer to the dimension table at the end of this catalog for sizes and options.

① ②

- ① Board Size
- 62 . . . 620 × 517 mm ● GS 621
- 54 . . . 540 × 445 mm ● GS 622
- 49 . . . 490 × 400 mm ● GS 541
- ② Tiers ● GS 542
- 1 . . . 1 Step ● GS 491
- 2 . . . 2 Steps ● GS 492



• GB540 + SM-3TX



Grand Base

GB 490

○ Please refer to the dimension table at the end of this catalog for sizes and options.

◎ Board Size ◎ All heights are 110mm

- ◎ 62 . . 620 × 517 mm ● GB 620
- ◎ 54 . . 540 × 445 mm ● GB 540
- ◎ 49 . . 490 × 400 mm ● GB 490



Lightweight and strong titanium pipe

The frame uses a Titanium pipe with a diameter of 32mm and a thickness of 1mm. It has the following advantages, and we believe that it is the best material for audio racks.

- Because it is lightweight, it is easy to control vibration.
- High strength ● Non-magnetic
- There is little character added to the sound, which is peculiar to the material.
- Resistant to rust
- Uses a single piece of pipe. Therefore, there is little worry about deterioration over time



Vibration control treatment inside the pipe

Three damping treatments are applied to the inside of all titanium pipes. Vibration control, which is more difficult with a robust frame, has been achieved with minimal weight increase.

- ① Silicon coating on the inner wall → Uses silicon materials carefully selected through audition. It suppresses the vibration of the whole pipe and the resonance sound inside.
- ② Arrangement of "Cancel Ball" → A "Cancel ball" is installed on the inner wall of the center of the pipe and silicon coating. Metal balls and pipes that move somewhat freely cancel out each other's vibrations. It is an application of Silent Mount Technology (see page 15).
- ③ Insertion of sound absorbing material → After the above two treatments, Australian wool is inserted into the cavity to prevent internal resonance. It is a lightweight material that does not carry a unique tone.



Shelves made of special laminated plywood

This is a special laminated plywood that was developed with the highest priority on ensuring sufficient strength and not coloring the reproduced sound with the material's unique character.

In addition, in order to dampen and reduce the weight of the shelf board itself, and to prevent resonance between the equipment and the shelf board, an asymmetrical opening is provided in the center (for the KT type top board).

In addition to the standard "KT" type, various shapes are available for the shelf board. Available in 2 thicknesses and 3 colors. For details, see the "Dimensions Table" at the end of this catalog.



Structural adhesives for frame

We do not use metal welding or screws in frame construction (joints and pipes) in order to prevent noise and sound / image turbidity.

■ Metal welding : Expansion / contraction due to heat occurs only at the welded part. Therefore, by the time the frame is assembled and cooled, distortion (stress) remains in the entire frame.

■ Screwing : It is difficult to secure strength, and the strength decreases as the screws loosen over time. Also, there is a big difference in strength depending on how it is assembled.

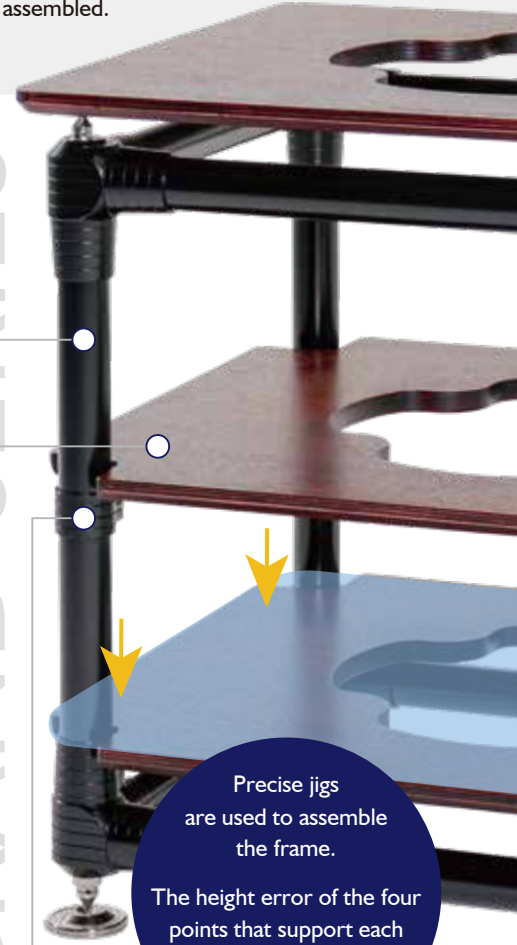

GRAND SERIES

Precise jigs are used to assemble the frame. The height error of the four points that support each shelf board is suppressed to 0.1 mm or less.

Middle and bottom brackets

Grand Tower also uses custom-made extra super duralumin brackets to support the shelves in the middle.

As with the "Corner joint", it is manufactured by precision machining from Extra super duralumin A7075. While using a structural adhesive (3M™ Scotch-Weld™ Structural Glue DP-460), it is firmly fixed to the titanium pipe with strict positioning (horizontal, left and right).

assembling

We use a high-strength ultra high cost structural adhesive (3M™ Scotch-Weld™ Structural Glue DP-460) to assemble the frame.

It is also used in aircraft and racing cars, and can be assembled without stress while maintaining sufficient strength for a long time.



Spike mounts are sold separately

are of Extra super duralumin



Bottom Bracket ↓

Extra super duralumin A7075 "Corner joint"

In any tubular table construction it is extremely important to rigidly join all the elements together. To maintain this rigidity each corner section has been milled from a solid block of A7075 Extra super duralumin one of the strongest Aluminium alloys. This is a slow complex process, with each corner joint taking 6 hours of machining to produce.

This no compromise approach for every corner piece results in an extremely strong and rigid frame. It also helps to maintain the low mass construction that we feel is fundamental to the Grand Tower's performance.



The joint also fits over the tube rather than inside (as used in our Rigid series). This change also greatly increases the bonding area between the component parts. This in turn provides the highest rigidity to the joints.



Spike support

Spikes system is the surest method to support boards and rack frame with two advantages.

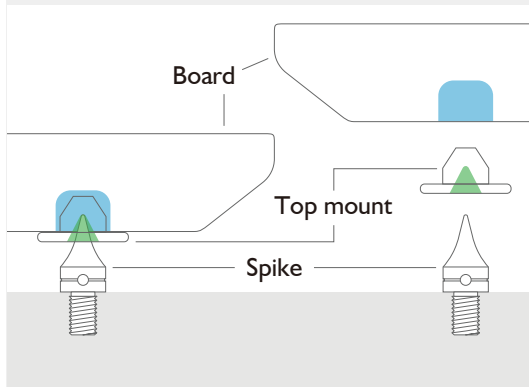

Minimum vibration interference from loudspeakers to rack through the floor as well as between the components.

Easiest and surest rack installation with highest stability and no wobbling.

As explained above, we believe the spike support is the indispensable method for audio and video equipment installation.



The spikes for the shelves and the "Top mounts" that receive them are selected from over 1,000 pieces and matched with a digital vernier caliper (with an accuracy of 0.01 mm) to use. This is an essential point in pursuing distortion-free installation.

A precision height adjustment mechanism is used for the spikes on the legs. The pitch (the distance the screw travels in one rotation) is finer than usual, and it is designed to allow fine and easy adjustment. After adjustment, it is firmly integrated into the frame with a hexagonal wrench. Robust, rattle-free installation supports the performance of racks and equipment.

RT683 • ALT600 • ALB12
(Spike mounts are sold separately)



RIGID SERIES

Overview (See next page for technical details)

Rigid series, the first Andante Largo product. As a result of placing the utmost importance on "light weight, robustness, compactness, and damping," the product has become far removed from a commercial point of view, such as the expandability and distribution of general racks.

At the same time, as a rack that thoroughly pursues sound quality, it has been a long-selling product for more than 15 years.



2008
1st generation of Rigid Table
for Linn LP12

Rigid Tower (Multi-tier rack)

RT 683 Mid

① ② ③

- ① Height : 68 • • • • • 68 cm
- ② Tiers : 3 • • • • • 3 steps
- ③ Board Size : (No notation) • 600 × 480 mm
Mid • • • • • 520 × 410 mm

- RT 865 ● RT 684 ● RT 503
- RT 865 Mid ● RT 684 Mid ● RT 503 Mid
- RT 864 ● RT 683 ● RT 502
- RT 864 Mid ● RT 683 Mid ● RT 502 Mid

○ Please refer to the dimension table at the end of this catalog for sizes and options.

RT865



• ALT12 + Solid Base Attachment

Rigid Table (Table for players)

ALT 520

◎ Board Size

- ◎ 600 ••••• 600 × 480 mm ● ALT 600
- ◎ 520 ••••• 520 × 410 mm ● ALT 520
- ◎ 12 ••••• 470 × 370 mm ● ALT 12

- ◎ All heights are 465mm
- Please refer to the dimension table at the end of this catalog for sizes and options.

ALT600



Rigid Base

ALB 600 / 2

① Board Size ② Height

- ① 600 ••••• 600 × 480 mm
- ① 520 ••••• 520 × 410 mm
- ① 12 ••••• 470 × 370 mm
- ② (No notation) : 90mm
- ② / 2 : 130mm

- ALB 600
- ALB 520
- ALB 12
- ALB 600 / 2
- ALB 520 / 2
- ALB 12 / 2

○ Please refer to the dimension table at the end of this catalog for sizes and options.

ALB12

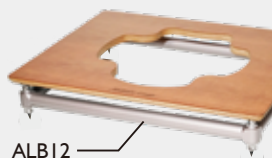

• ALB520 + SM-3TX



Lightweight and strong titanium pipe

The frame uses a Titanium pipe with a diameter of 25mm and a thickness of 1mm. It has the following advantages, and we believe that it is the best material for audio racks.

- Because it is lightweight, it is easy to control vibration.
- High strength ● Non-magnetic
- There is little character added to the sound, which is peculiar to the material.
- Resistant to rust
- Uses a single piece of pipe. Therefore, there is little worry about deterioration over time



Vibration control treatment inside the pipe

Three damping treatments are applied to the inside of all titanium pipes. Vibration control, which is more difficult with a robust frame, has been achieved with minimal weight increase.

- ① Silicon coating on the inner wall → Uses silicon materials carefully selected through audition. It suppresses the vibration of the whole pipe and the resonance sound inside.
- ② Arrangement of "Cancel Ball" → A "Cancel ball" is installed on the inner wall of the center of the pipe and silicon coating. Metal balls and pipes that move somewhat freely cancel out each other's vibrations. It is an application of Silent Mount Technology (see page 15).
- ③ Insertion of sound absorbing material → After the above two treatments, Australian wool is inserted into the cavity to prevent internal resonance. It is a lightweight material that does not carry a unique tone.



Shelves made of special laminated plywood

This is a special laminated plywood that was developed with the highest priority on ensuring sufficient strength and not coloring the reproduced sound with the material's unique character.

In addition, in order to dampen and reduce the weight of the shelf board itself, and to prevent resonance between the equipment and the shelf board, an asymmetrical opening is provided in the center (for the KT type top board).

In addition to the standard "KT" type, various shapes are available for the shelf board. Available in 2 thicknesses and 3 colors. For details, see the "Dimensions Table" at the end of this catalog.



Structural adhesives for frame

We do not use metal welding or screws in frame construction (joints and pipes) in order to prevent noise and sound / image turbidity.

- Metal welding : Expansion / contraction due to heat occurs only at the welded part. Therefore, by the time the frame is assembled and cooled, distortion (stress) remains in the entire frame.
- Screwing : It is difficult to secure strength, and the strength decreases as the screws loosen over time. Also, there is a big difference in strength depending on how it is assembled.

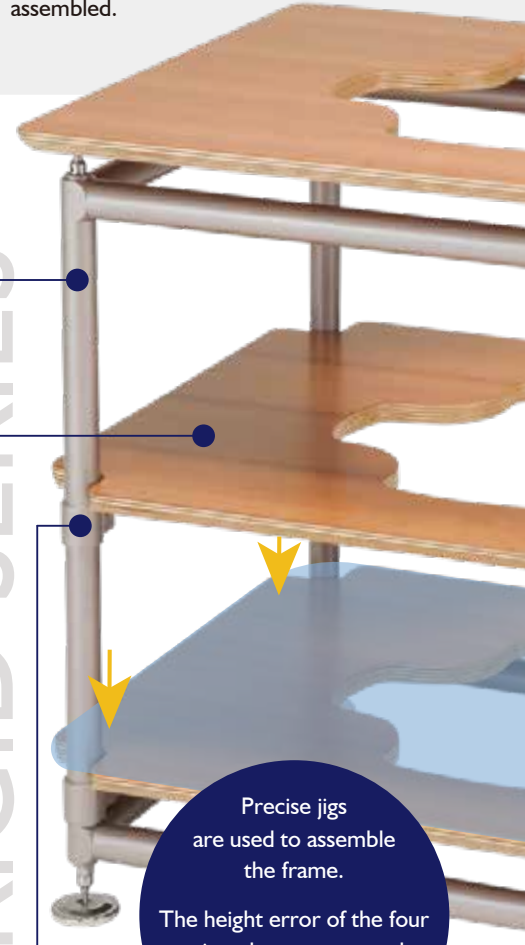

RIGID SERIES

Precise jigs are used to assemble the frame.

The height error of the four points that support each shelf board is suppressed to 0.1 mm or less.

Middle and bottom brackets

Rigid Tower uses custom-made Extra super duralumin brackets to support the shelves in the middle and bottom.

It is manufactured by precision machining from Extra super duralumin A7075. While using a structural adhesive (3M™ Scotch - Weld™ Structural Glue DP-460), it is firmly fixed to the titanium pipe with strict positioning (horizontal, left and right).

assembling

We use a high-strength ultra high cost structural adhesive (3M™ Scotch-Weld™ Structural Glue DP-460) to assemble the frame.

It is also used in aircraft and racing cars, and can be assembled without stress while maintaining sufficient strength for a long time.



Spike mounts are sold separately

are Extra super duralumin



Aluminum die-cast "Corner joint"

The 3-way (2-way) "Corner joint" used at the corner of the frame is manufactured by precision machining from aluminum die-cast. It is designed after thorough research on how stress is applied, achieving both lightness and robustness.

Innumerable grooves are arranged at the joint with the pipe to dramatically improve the bonding strength.



Spike support

Spikes system is the surest method to support boards and rack frame with two advantages.

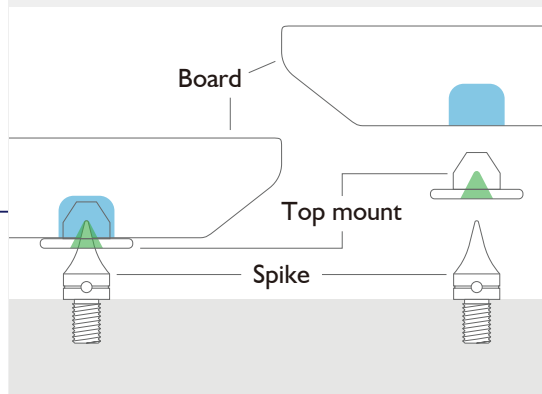

Minimum vibration interference from loudspeakers to rack through the floor as well as between the components.

Easiest and surest rack installation with highest stability and no wobbling.

As explained above, we believe the spike support is the indispensable method for audio and video equipment installation.



The spikes for the shelves and the "Top mounts" that receive them are selected from over 1,000 pieces and matched with a digital vernier caliper (with an accuracy of 0.01 mm) to use. This is an essential point in pursuing distortion-free installation.



A precision height adjustment mechanism is used for the spikes on the legs. The pitch (the distance the screw travels in one rotation) is finer than usual, and it is designed to allow fine and easy adjustment. After adjustment, it is firmly integrated into the frame with a hexagonal wrench. Robust, rattle-free installation supports the performance of racks and equipment.



As an option, we offer a high-performance model "Titanium top mount" for the spike receiver (top mount) for the shelf board (stainless steel is included as standard). For details, refer to the "Dimensions Table" at the end of this catalog.



SILENT MOUNT

Why many High-end components use Spikes ?

● Stable installation of loudspeakers

- Stable installation greatly reduces unwanted cabinet movement. Extremely important in ensuring the drive units are pushing the correct amounts of air.
- Even when resonance occurs, it can be damped and stopped more effectively.

● Helps control vibration transmission for components

- Many devices suffer from microphony. Controlling the transmission of vibrations either from or to equipment can result in worthwhile musical performance improvements.
- Vibration transmission from speakers to Record players and amplifiers can be significantly reduced and provide substantial improvements.

In this way, spike legs are the best method for installing audio and video equipment because they can efficiently cut vibrations while stably installing the equipment.

Spikes need stable mounts to work !

All SilentMount models are machined from high quality durable materials. This ensures that they have the strength to rigidly support all but the most extreme mass components. Great care has been made over the geometry of the mount to ensure a very good mechanical connection.

- **Low center of gravity design** → The spike connects to the top of the silent mount plate at the bottom of a conical recess. The center of gravity of this recess has been designed to offer the lowest centre of gravity within the body of the silent mount. The lower this center of gravity the more stable the interface.

The technology of “Silent” Mount

The metals that can hold spikes firmly are all materials that naturally can resonate fairly easily, This ringing is in effect storing energy and feeding it back into the spike and the structure the spike is supporting. This unfortunately adds a colouration to the sound.

- **Adoption of “Silence” technology** → The careful matching of the two metals (Main body and "Resonance cancellation ring") that make up the silent mount and their bonding together provides a very effective damping system that greatly reduces resonances within the silent mount. All aspects of the matching and geometries have been developed through repeated research on materials and shapes.

It has both “Strength” and “Vibration damping” to firmly support the spikes.

We believe that adding "Silent"Mounts to your support systems will further help you to bring out more of the original expression that the performer wanted to convey, from the biggest most dynamic sounds down to the most delicate reverberations.

Differences in design depending on the purpose

The design requirements for spike mounts are very different depending on what they are supporting. When working with speakers (obviously a large source of vibration) the silent-mount requires a wider diameter both to support the speaker properly and absorb the high levels of vibration being generated by the speaker.

At the equipment support it is important to limit the amount of vibration that reaches the equipment. This is especially important when using a record player as the source. These silent mounts therefore have a much smaller diameter and are optimised differently.

● For speakers

- In order to firmly support the weight of the main unit and powerful vibrations, a wide design.

● For rack, player and amplifier

- Compact and lightweight design that is stable and resistant to vibration from speakers.

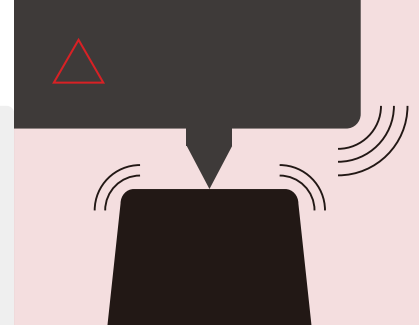

The position to receive the spike is High → **Unstable**

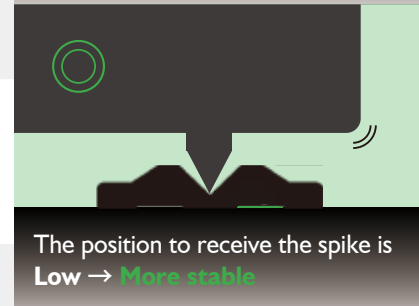

The position to receive the spike is Low → **More stable**

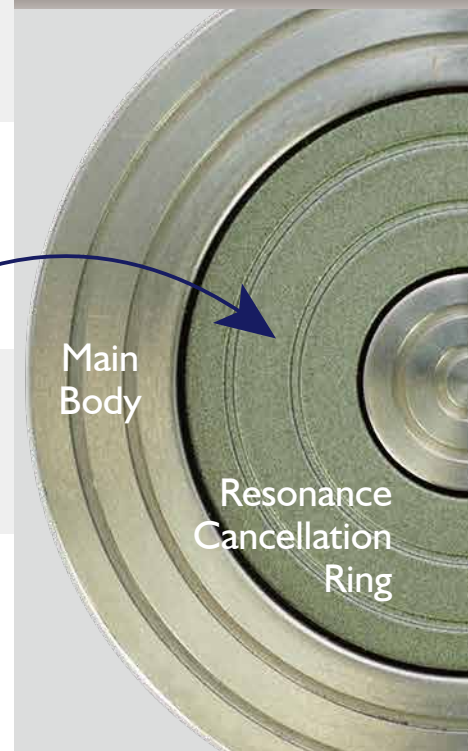

SM-5X





Silent Mount SM-5X

Standard model for racks and amplifiers.

- Material Selected Stainless Steel with alloy damper
- Construction Bi-metal double layered structure
- Finish Black
- Optimised for Equipment Racks and amplifiers
- Spikes Spikes with less than 70° points
- Load capacity Up to 80kg per mount
- Accessories Felt floor protectors / installation tools
- Weight 100g each
- Qty Multiples of 4

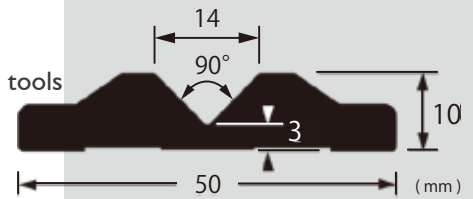

Silent Mount SM-5TX

Flagship model for racks and amplifiers.
Machined titanium

- Material Titanium with alloy damper
- Construction Bi-metal double layered structure
- Finish Polished titanium
- Optimised for Equipment racks and amplifiers over 25kg
- Spikes Spikes with less than 70° points
- Load capacity Up to 80kg per mount
- Accessories Felt floor protectors / installation tools
- Weight 60g each
- Qty Multiples of 4

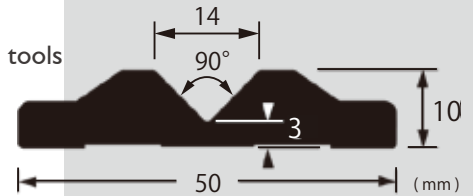

Silent Mount SM-3TX

High-end model optimised for Light equipment and rack systems such as player tables. High quality Machined titanium. The best for lightweight loads with a total weight of 25 kg or less.

- Material Titanium with alloy damper
- Construction Bi-metal double layered structure
- Finish Polished titanium
- Optimised for Equipment racks and amplifiers under 25kg
- Spikes Spikes with less than 100° points
- Load capacity Up to 30kg per mount
- Accessories Felt floor protectors / installation tools
- Weight 20g each
- Qty Multiples of 4

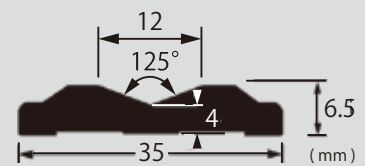

Silent Mount SM-7X

For loud speakers.

- Material Selected Stainless Steel with alloy damper
- Construction Bi-metal double layered structure
- Finish Black
- Optimised for Loud speakers
- Spikes Spikes with less than 70° points
- Load capacity Up to 150kg per mount
- Accessories Felt floor protectors / installation tools
- Weight 240g each
- Qty Multiples of 4

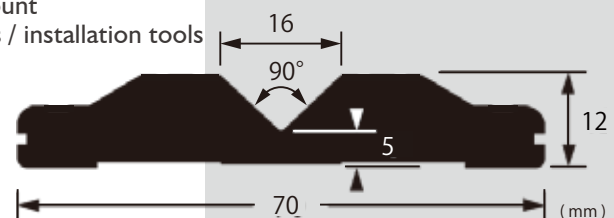

Accessories

● Felt floor protectors (Supplied with all Silent Mounts)

When using for a **rack, record player, or amplifier**, on to if the installation surface is a relatively **hard surface** such as wood flooring, stone, or an equipment shelf board, **attach a felt sticker** as this will perform better as well as offering further protection to the surface.



When the rack is being installed on a carpeted surface, we do not suggest using the floor protectors.

When using with loud speakers / speaker stands, the best results are obtained without the floor protector whatever the floor covering.

● Installation clamp tool (Supplied with SM-5X • SM-5TX • SM-7X)

A dedicated mounting tool that is convenient for installation in hard-to-reach places such as larger speaker cabinets and underneath large amplifiers. It aids placement directly below the spike during installation. It is attached to the silent mount by inserting it into the two holes on the side of the mount.

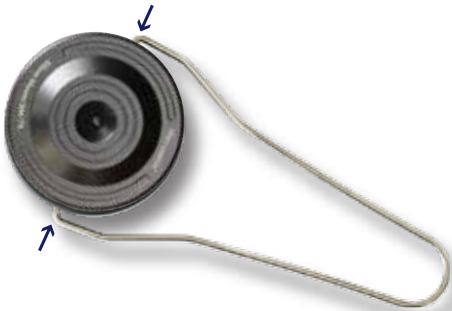

SM-3TX + Rigid Base



SM-7X



SM-5TX + Grand Tower



Related items

● Through-Hole spike series (Next Page)

Precision machined spikes incorporating features developed from our work during development of our audio racks and turntable tables. By using far better materials and precision engineering of both the spikes and nuts as well as having a cross hole allowing easy accurate adjustment.



They are available in various sizes and thread types so providing upgrades to many different speaker stands and rack systems. Each pack contains 4 Spikes & Nuts, and installation tools.

Silent Mount SM-7FX

For loud speakers of obtuse angle spike and flat foot.

- Material Selected Stainless Steel with alloy damper
- Construction Bi-metal double layered structure
- Finish Black
- Optimised for Loud speakers
- Spikes Spikes with less than 110° points
- Load capacity Up to 150kg per mount
- Accessories Felt floor protectors / installation tools
- Weight 240g each
- Qty Multiples of 4

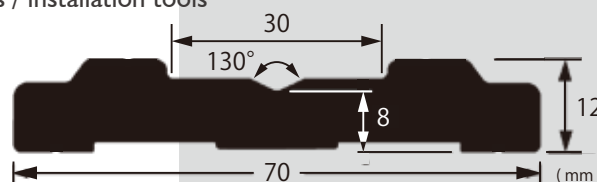



THROUGH-HOLE SPIKE

Lineups

[mm]

- TS-M6
- TS-M8
- TS-M10
- TS-M10-Q
- TS-M12
- TS-M12-J

[inch]

- TS-1/4
- TS-5/16
- TS-3/8
- TS-1/2

Set of 4 with
 • "Tommy Bar"
 • Spanner



	A	B	C	D	E	F	G	H	M
M6	6	1.0	36	14	22	11	11	5	50
M8	8	1.25	40	18	22	13	13	5	50
M10	10	1.25	44	22	22	15	17	6	80
M10-Q	10	1.5	44	22	22	15	17	6	80
M12	12	1.25	44	22	22	16	19	6	80
M12-J	12	1.25	29	13	16	16	19	6	80
1/4	1/4"	1.27	36	14	22	11	11	5	50
5/16	5/16"	1.41	40	18	22	13	13	5	50
3/8	3/8"	1.59	44.5	22.5	22	15	17	6	80
1/2	1/2"	1.81	44.5	22.5	22	16	19	6	80

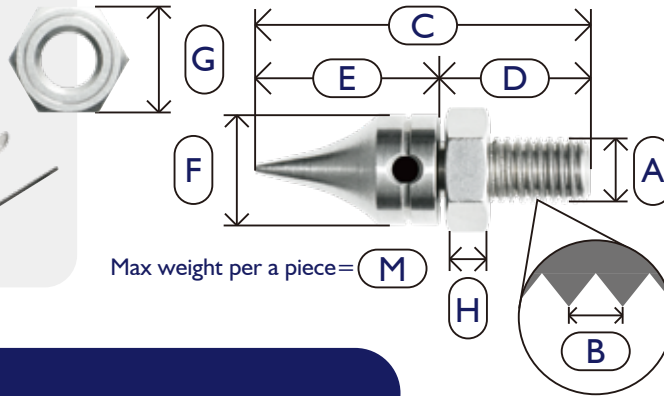

• TS-M6



• TS-M8 & TS-M6



Details

The design of the through-hole spikes is based on the various know-how that Andante Largo acquired during rack development. **In particular, the "through-hole" structure in which the shaft is hollow has achieved ideal vibration control.**

With the commonly seen height adjustment mechanism that can be simply turned by hand, the spikes themselves wobble or resonate (because they are not fixed to the bottom of the device). This also has a negative effect on the operation of the device itself, which greatly impairs sound and image quality.

Andante Largo's through-hole spikes come with a special tool that allows precise height adjustment, and after adjustment, tighten the nut to firmly integrate with the bottom of the device. **This takes full advantage of the inherent advantages of the spike structure, "vibration damping" and "stable installation".** The material used is special stainless steel that was carefully selected through listening tests.

Excellent vibration control with the "through-hole" structure and sturdy installation without wobbling using special tools will significantly upgrade your system. Additionally, when used in conjunction with Silent mount (Page 14), even better vibration control and stable installation are possible.

• TS-M10-Q



How to install

● Detailed installation and adjustment methods are introduced in the instruction manual.

① **Temporary fixing** : Insert the included tool into the hole on the side and turn the spike to adjust the height. Check the level of the rack or speaker. Front and back as well as left right. It is generally good practice to try to keep the spikes as far in their mounting holes as possible when achieving this.



② **Locking the Spikes** : Lock down the two back spikes BUT only one of the front spikes. Use the "Tommy bar" to stop the spike from turning while you tighten the machined nut with the spanner provided. (Please be careful not to apply excessive force when tightening as this may cause damage.)



SUPER-TMD

Lineups

- STMD - 1.5 1.5ml
- STMD - 3 3ml
- STMD - 10 10ml

- ◎ The expiration date is indicated on the bottom of the package
- ◎ Comes with few sample cotton buds and paper towels



STMD-3



How it works?

Even though the contact points of plug and socket surface may look shiny to the naked eye, it will look very uneven when viewed under an electron microscope. If you connect these contacts together, you can imagine that countless fine contact failures will occur.

What makes this even worse is the bad effects of vibration during music and video is played back. When poor contacts are shaken and touched or separated to each others, the signal path changes rapidly, and the phase etc. becomes disjointed, making the music and video information remarkably distorted (Right upper figure).

Super TMD, which is based on conductive polymer, penetrates into the minute irregularities on the terminal surface. By expanding the contact area and strengthening the ground, the number of "reliable contacts" are increased and information can be transmitted far more stably (Right lower figure).

Recommended for a wide range of audio and video equipment Plugs, terminals (RCA / XLR / BNC / USB / LAN / any contacts of cartridges and tonearms / loudspeakers / amplifiers/ power supplies / vacuum tubes, etc.).

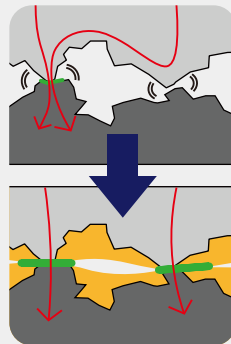

● Component
 — Conductive point
 → Signal flow
 (Image diagram)

How to use?

- Before actually using the product, be sure to read the precautions described in the instruction manual and use it correctly.

① **Apply** : Always, shake the bottle very well each time before you start to use. Only treat the metal contact surfaces of the connector. There is no benefit in applying excessive quantities. Any SuperTMD spilt onto the insulation surfaces should be wiped off before drying.

② **Wipe off** : After more than 10 minutes, gently wipe off the dried fluid gently with a cotton buds and papers, and you're done. You can use it immediately after that, but it takes 2-3 days for the maximum effect.

◎ **More effective "double treatment"**
 If you repeat the above process twice, it will enhance the effect far more and long durability. After completing above first process ① & ②, wait for an hour or more and then continue the second time process.

◎ As the regular maintenance of your Hi-Fi system, we recommend the STMD regular maintenance every 6 months a time (steps 1 and 2) in order to maintain the sound performance at its highest level.



① Apply

↓ 10 minutes

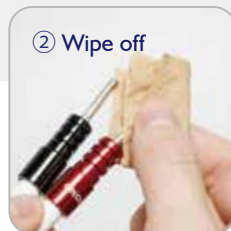

② Wipe off

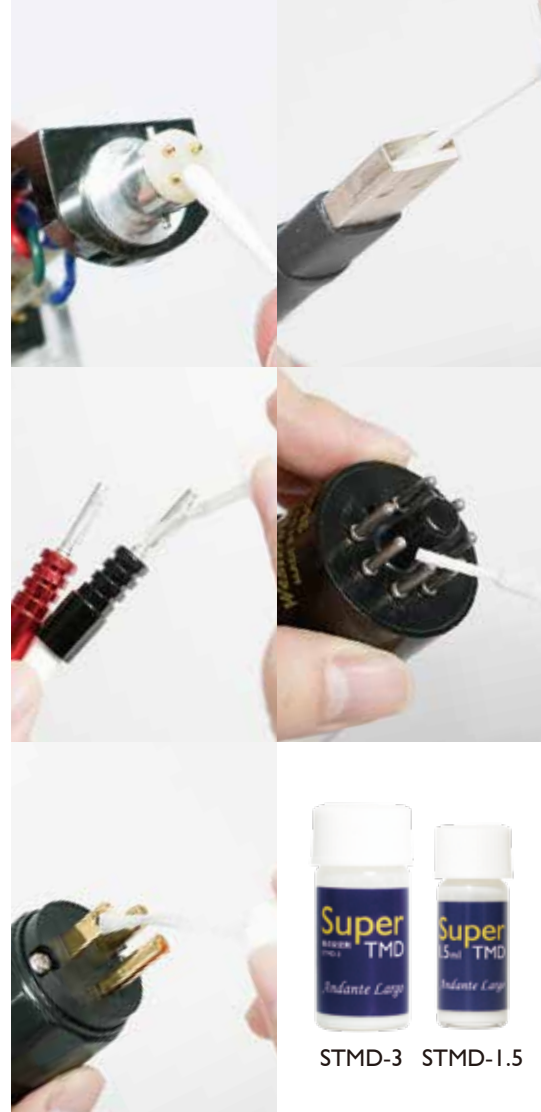

STMD-3 STMD-1.5



« How to Use ?





Examples of How To Use



ALT12 & SM-5X



GB620 & SM-5TX



GT744 & SM-5TX



How to Replace



GT683 & SM-5TX



GB540 & SM-3TX



RT683,GT503,GS541,GS491
WF320, ALB12 and S.M.



SM-7X



ALB12 & SM-5X



GB540 & SM-3TX

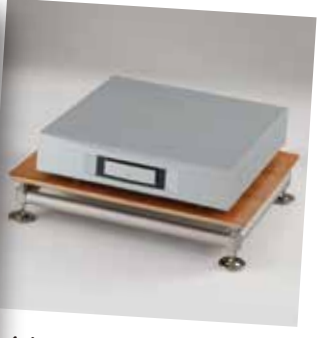

ALB12 & SM-5X



RT684
(EMT930 Board)



Through Hole Spike



GT683



RT683 & SM-5TX



RT683
& SM-5TX



GT744 & SM-5TX



GT744 & SM-5TX



ALT520 & SM-5TX



GT744



SM-7FX



GT744 & SM-5TX



GT502 & SM-5TX



RT684 & SM-5TX



GB540 & SM-3TX



ALB12/2 & SM-5TX



SM-7X



RT865
& ALB12/2



RT865, ALT600,
ALB12, and SM-5TX



SM-7FX



SM-7FX



RT503
& SM-5TX



ALT600, SM-5TX,
ALB12 and SM-3TX



SM-7X



SuperTMD



SuperTMD



SuperTMD



TS-M8 & SM-5X



RT683 & SM-5TX



Andante Largo Standard

How we evaluate our product during development

We consistently use three sound quality evaluation methods during the development of our own products as well as the evaluation of other audio products. This system is also very useful when setting up the hi-fi systems.

In order to provide “Good consistent sound” as a manufacturer, we first need to establish clear standards for what constitutes “Good sound.” We believe that by judging all our products with this same repeatable approach results in a common family sound and clear changes as you move upwards through our product ranges. If you like what one of products does then it is likely that you will like other members of our our ranges.

The following three methods are not exclusive to our company and are in fact the way that many people listen to live music. If you think it makes sense we hope that it will become a useful tool when choosing equipment or setting up your own system at home.

① Separation of “Musical instruments”

When setting up a system it can be very easy to focus on the positioning of instruments, where they are located between the speakers and how near or far away it seems in the recording. Although these effects can be observed to change when adjusting or adding to your system. We feel that there are other more important factors that need to be checked first.

When you listen to live music it is seldom the location of the instruments that people comment on. In fact the next time you are listening to live music like a guitar or piano close your eyes and listen for the “position and size” . You may well be surprised at just how hard it is to do. The instrument will tend to fill the room it will be surprisingly difficult to pinpoint where the guitar is being played. You will clearly hear beautiful tones and rich resonances (overtones) how loud each note is played how long it is held. In other words, in the original “natural sound” , the position of the instrument is often unclear.

However, once music is played from the system, people often say, “That person is singing here” , or “Instrument A is over there, and instrument B is here” . We believe that it is a condition in which there are not enough overtones. The closer you get to the real sound, the less important “Here” and “There” become. In fact, we believe that this is a “Natural sound” that is closer to the original sound.

Of course, it is not wrong to say that increasing accuracy means that you can point with your finger and know where you are. The problem, however, is that if you pursue just that, you may end up with a very precise but limited musical sound.

One of the things we place importance on is the separation between instruments. For example, when you listen to a quartet of instruments on regular audio, you may hear the sounds of each instrument overlapping each other. This overlapping results in it being very hard to follow the musician playing the quieter melodies. A typical situation when listening to a piano piece it can often be quite difficult to make out what the left hand of the player is doing.

The piano, drums, and bass in a jazz trio should also be clearly audible independently, rather than all as a whole. After all they have three different instruments and will be playing different melodies.

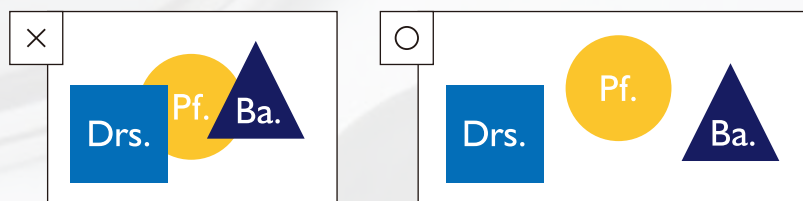

Even in a big band performance, if there is an acoustic guitar among the loud brass, the sound of that guitar should be clearly audible, even though it cannot match the volume of the brass section. Composers write that little melody in the score because they need that little melody to express the piece correctly. Therefore, regardless of the volume, it is important that the sounds of the instruments are reproduced clearly without overlapping each other.

② Separation of “One note before and after”

Another important separation is that of one note before and after. We believe that this separation is also extremely important. When a system is struggling voices will sound almost like they are talk singing or not putting any feeling into the performance.

In a good classical guitar performance, after playing one note, firmly grip the strings with your fingers to stop the note before playing the next note. It' s not “CDE” but “C · D · E” . Whether the tempo is fast or slow, they play “C · D · E.” This allows each note to resonate very clearly. (Andrés Segovia is a master who has perfected this technique and whether playing slowly or quickly, he played each note very clearly.

Glenn Gould also strictly separated each note in his playing. That is why each note of their performance sounded clear and beautiful even in extremely fast phrases.

It is exactly the same story for audio. For example, let us say you have speakers that are set up securely, so they do not wobble and are playing great music. Therefore, if you intentionally create a slight wobble between the speaker and the floor, the sound will be less accurate, and you will notice that it becomes much harder to follow the notes being played.

Playing each note before and after without mixing them ... This is an essential point in order to more fully experience the performers' technique and passion.

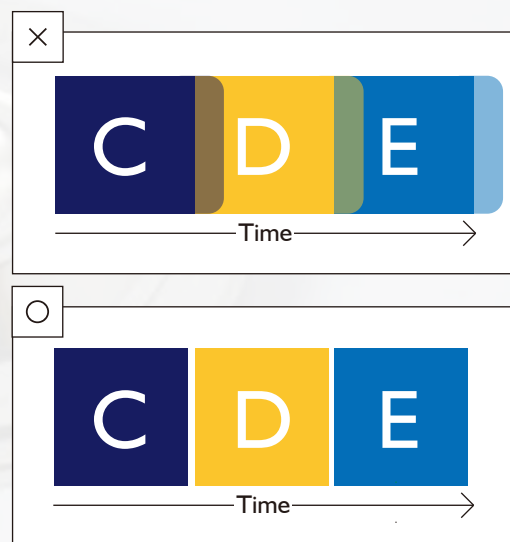

③ Separation of “High notes and low notes”

Next is the separation of the different pitches of the notes making up the melodies. Called High note or High frequency in various languages. I'm sure it is a word that has been used since ancient times, but regardless of language differences, people have probably felt that higher notes are naturally heard from higher up and have expressed it that way. This is a wonderful feeling that we humans are born with. Therefore, in sounds that are close to natural, high notes are heard from above, and low notes are heard from below, as if crawling on the ground.

Similarly, in a good system, “high notes” will be heard from far above the speaker, and “low notes” will be heard from far below the speaker. Conversely, if there is even a slight amount of distortion in the system, both high and low scales will only be heard from around the speakers.

Also, depending on how you perceive the sound, when the treble and bass are closer to the midrange, it may be considered “good” because it sounds powerful. However, if you apply it to the above story, I do not think it can be said to be the original musicality.

The song I would like you to listen to for reference is Paganini “24 Capriccio No. 5”. There is a beautiful phrase in which the melody of the violin gradually rises from the low strings, then rises higher, then rises again, and I think you can understand the sense of the rise and fall of the scale very well.

High notes resonate from a higher place, and low notes resonate from a lower place ... that's how you can fully enjoy the beauty of “contrast,” one of the most important elements in music.

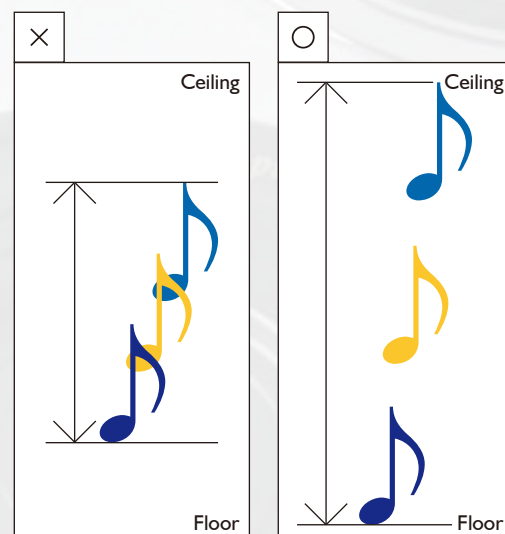

Focus your ears on the method and you will be able to discern slight differences in sound.

There are many people who say, “I do not really know much about settings, but I still love good sound and good music.” Even if that is not the case, hobbies are something you choose based on your own sensibilities, and you probably do not want others to criticize your choices. However, as a manufacturer, we need a repeatable method of judging sound. Whether during product development or quality control we can not just make a decision based on a vague feeling.

When developing a product, we select the best option from among many options. For example, when comparing five types of materials and choosing the best one, the only way to do so is to listen to the material blindly without any preconceived notions, rather than relying on characteristics that are known in advance. Taking an actual product as an example, when designing the spike mount “Silent Mount”, we created dozens of prototypes with very complex combinations, and selected the best one after listening to it. We also tested more than 30 prototypes with regard to the hollowed-out shape of the top plate of the racks, as well as the selection of materials and adhesives. During the development of all these products every change made resulted in repeatable changes to the sound as explained above.

When I talk about this to third parties, they say, “Do you understand that subtle difference?” In fact, some comparisons appear to show only a small quantitative difference. However, if you focus on the three points mentioned above and listen and compare, even the slightest difference will be brought into close focus and with a little practice you will be able to judge whether it is better or worse with a high level of confidence. **Please try it once you will be surprised at how clear the differences are and how it lets you choose with greater confidence.**



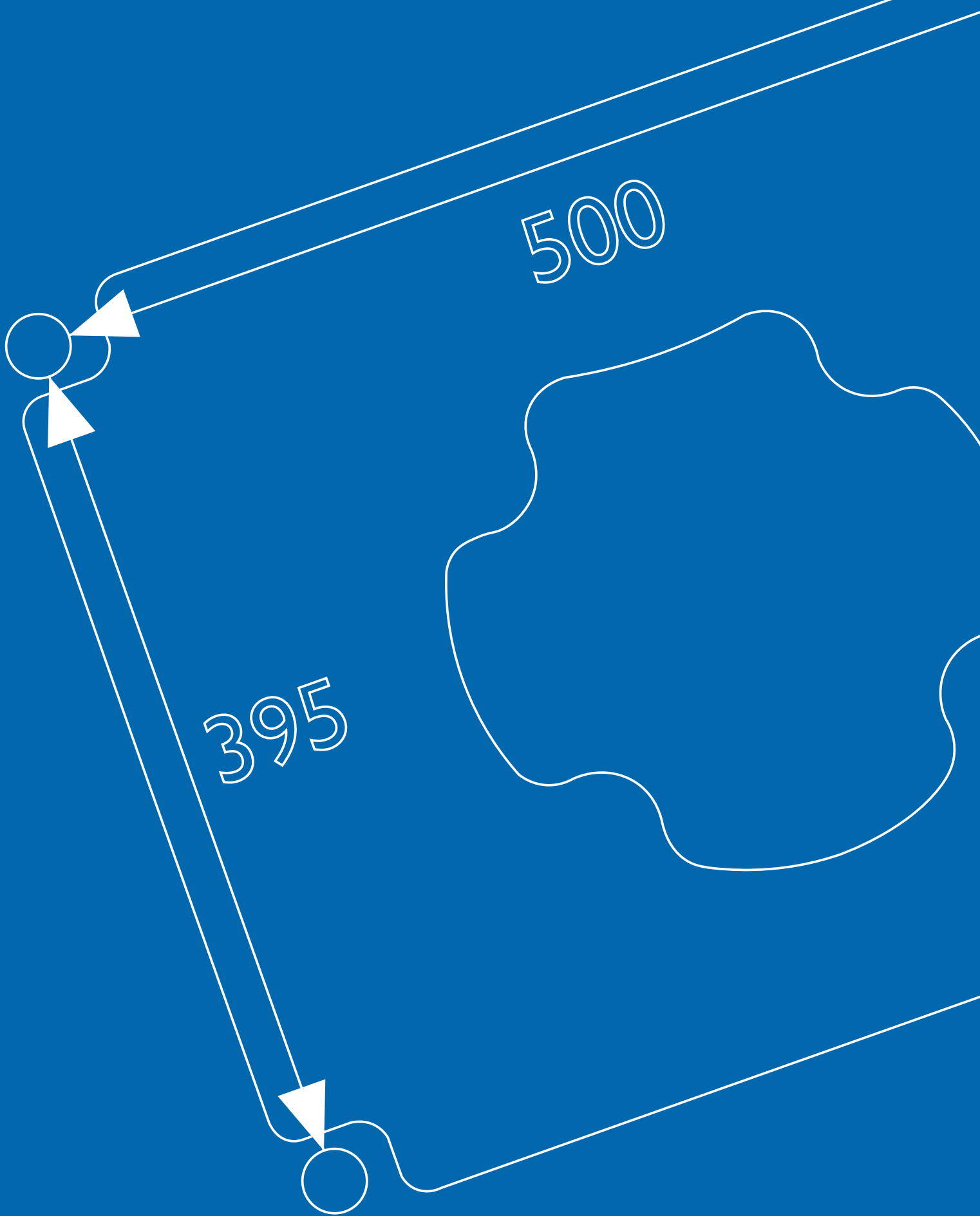

Dimensions & Options

- Load capacity of the entire rack : 250 kg
- Withstand load per board (when extra thick plate is used)
 - Equipment with 4 feet : 50kg (80kg)
 - Equipment with 3 feet / Multiple units : 40kg (70kg)
- See page 38 for extra-thick board

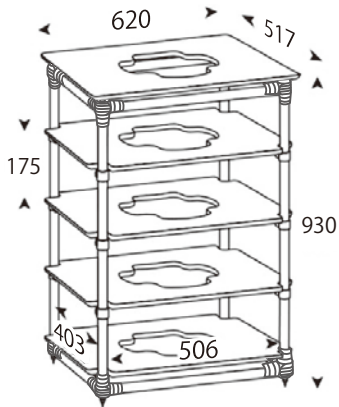

GT935

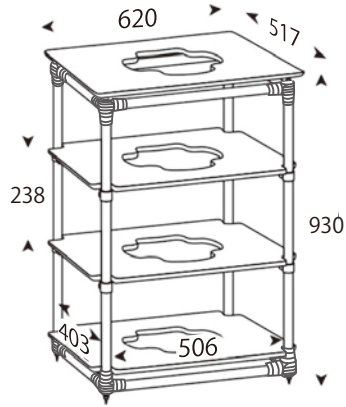

GT934

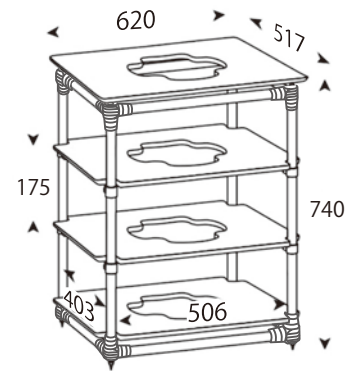

GT744

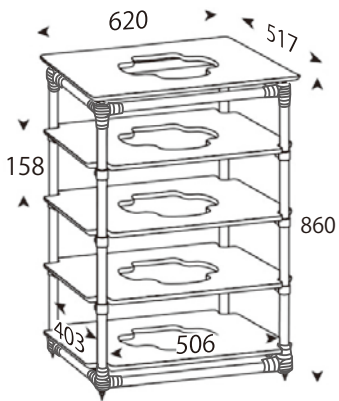

GT865

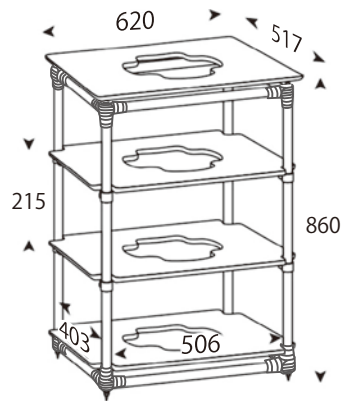

GT864

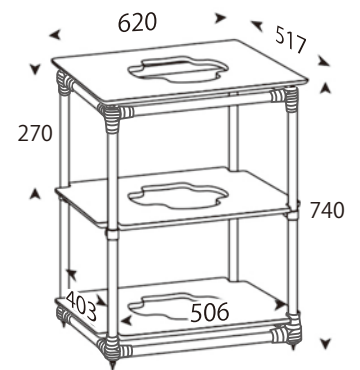

GT743

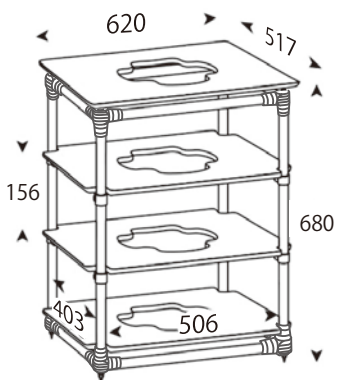
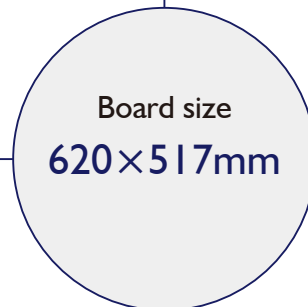
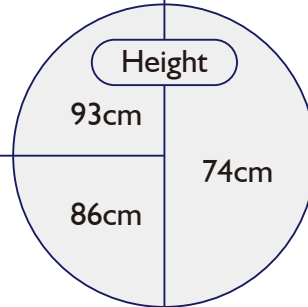

GT684

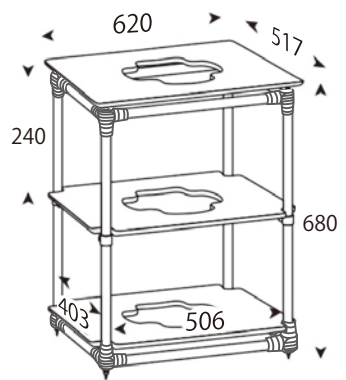

GT683

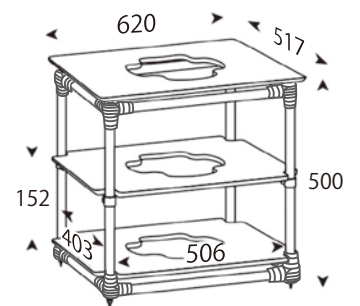

GT503

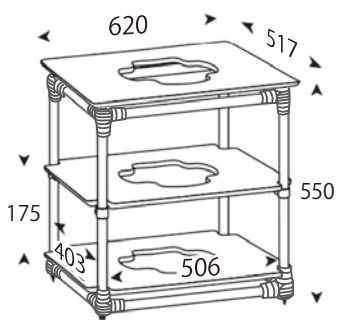
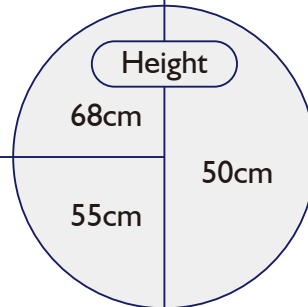

GT553

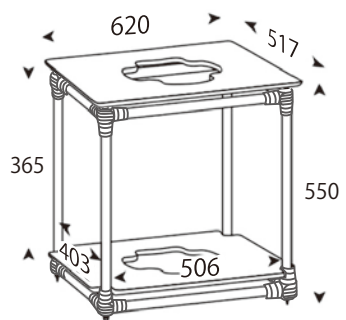

GT552

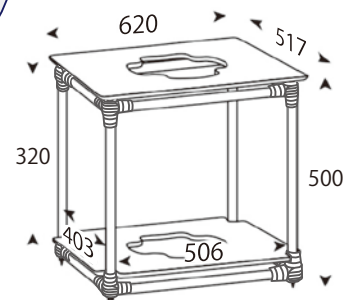

GT502

Grand Tower Mid (Page 6)

- Load capacity of the entire rack : 250 kg
- Withstand load per board (when extra thick plate is used)
 - Equipment with 4 feet : 50kg (80kg)
 - Equipment with 3 feet / Multiple units : 40kg (70kg)
- See page 38 for extra-thick board

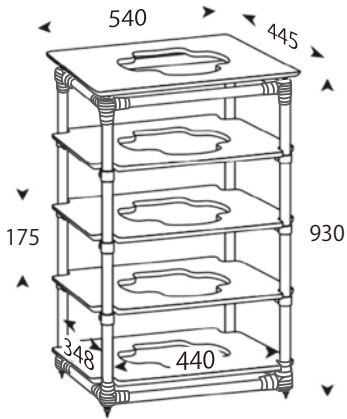

GT935 Mid

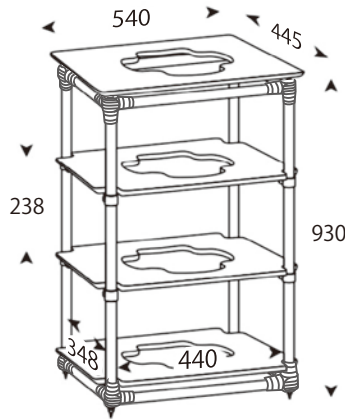

GT934 Mid

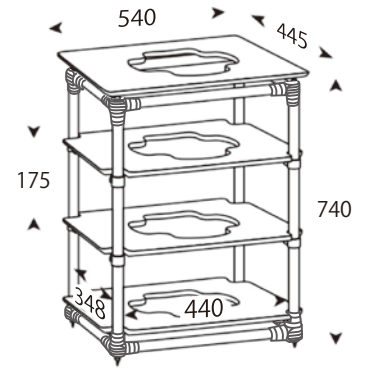

GT744 Mid

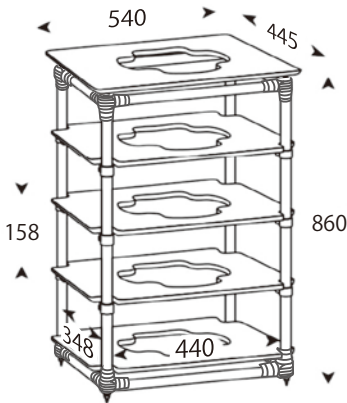

GT865 Mid

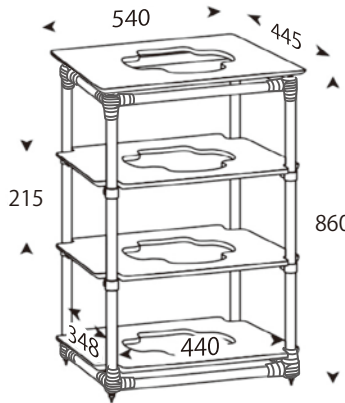

GT864 Mid

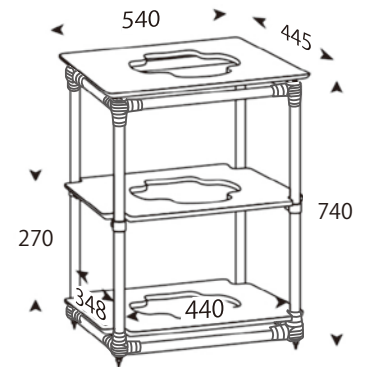

GT743 Mid

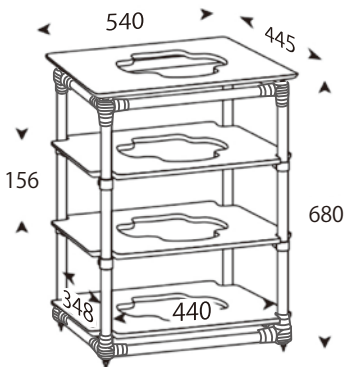
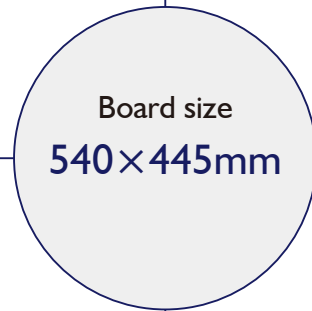
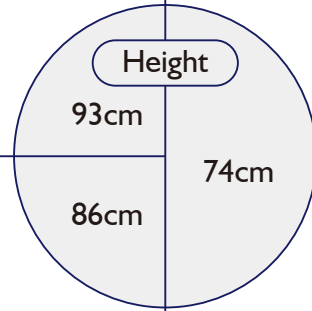

GT684 Mid

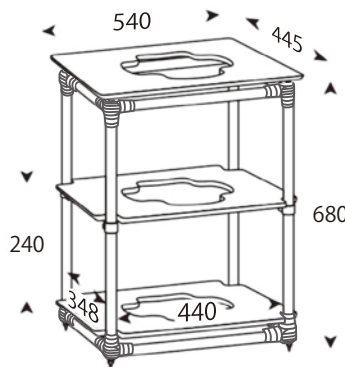

GT683 Mid

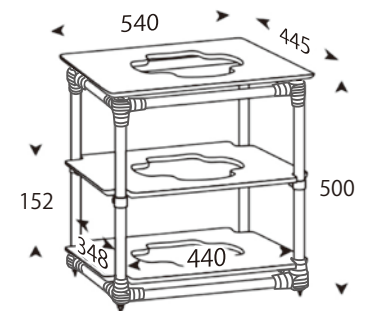

GT503 Mid

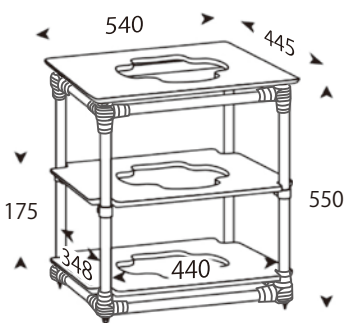
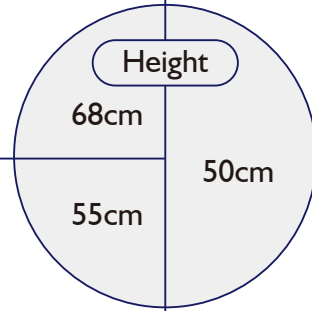

GT553 Mid

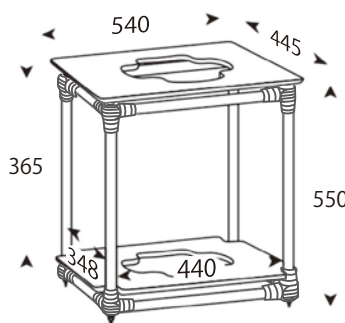

GT552 Mid

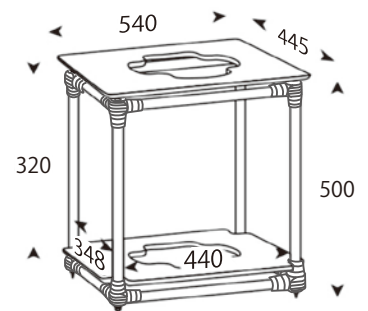

GT502 Mid

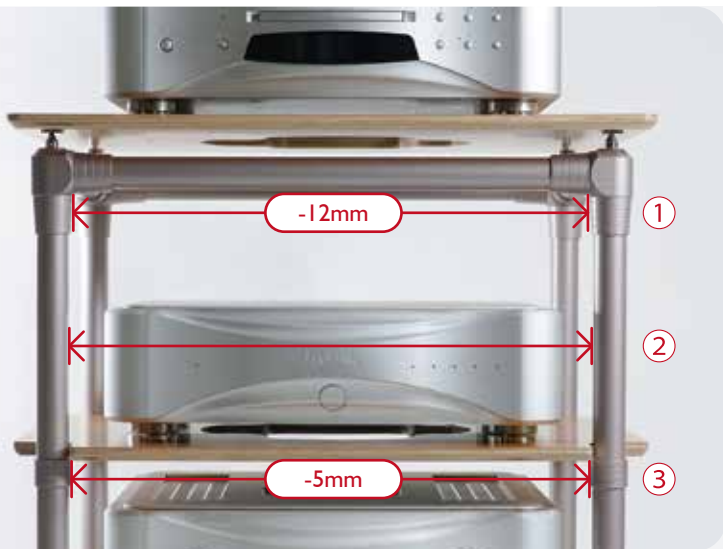

Notice (Grand Tower / Grand Solo)

The internal width of racks can be smaller depending on the shapes as shown in the pictures.

- Width ① is -12mm less than ②
- Width ③ is -5mm less than ②
- The space ④ is -6mm less than ⑤

The internal width and space of all the racks are showing the values of ② & ⑤.

Exception : Extra-thick board will have -3mm space of the value shown in each drawings.

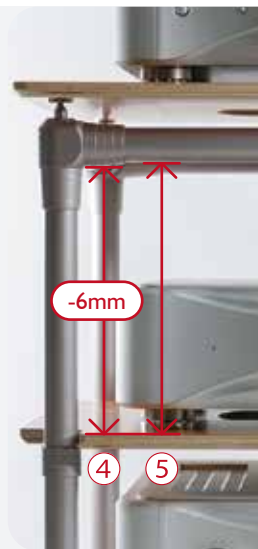

Grand Solo (Page 6)

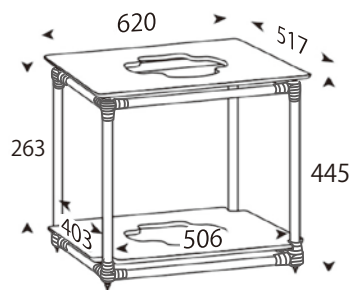

GS622

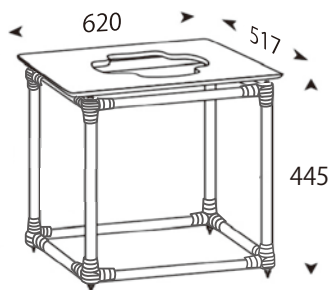

GS621

- Load capacity of the entire rack : 160 kg
- Withstand load per board (when extra thick plate is used)
 - Equipment with 4 feet : 50kg (80kg)
 - Equipment with 3 feet / Multiple units : 40kg (70kg)
- See page 38 for extra-thick board

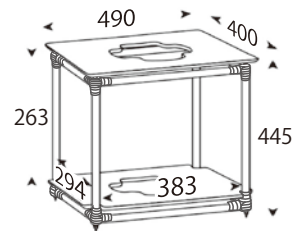

GS492

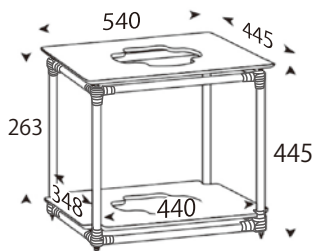

GS542

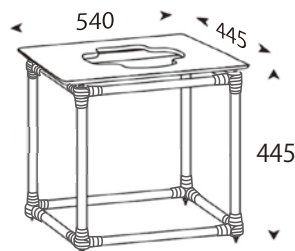

GS541

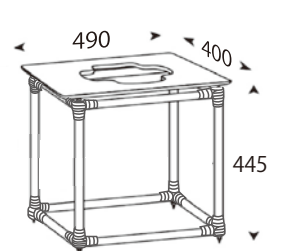

GS491

Grand Base (Page 6)

- Withstand load per board (when extra thick plate is used)
 - Equipment with 4 feet : 70kg (120kg)
 - Equipment with 3 feet / Multiple units : 50kg (100kg)
- See page 38 for extra-thick board

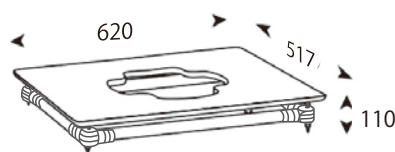

GB620

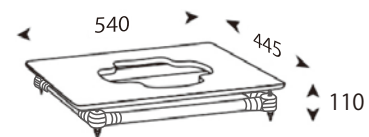

GB540

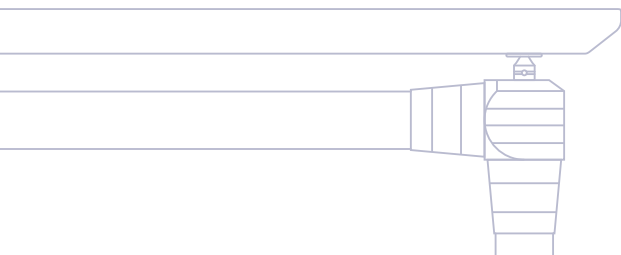

Rigid Tower (Page 10)

• The internal width will be -4mm less between the board brackets.

- Load capacity of the entire rack : 250 kg
- Withstand load per board (when extra thick plate is used)
 - Equipment with 4 feet : 50kg (80kg)
 - Equipment with 3 feet / Multiple units : 40kg (70kg)
- See page 38 for extra-thick board

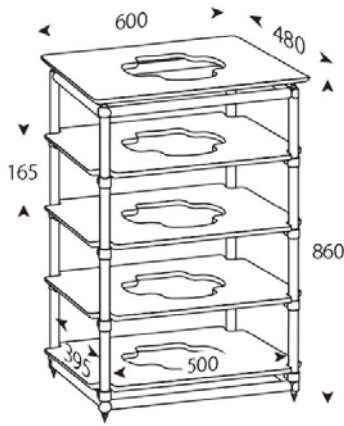
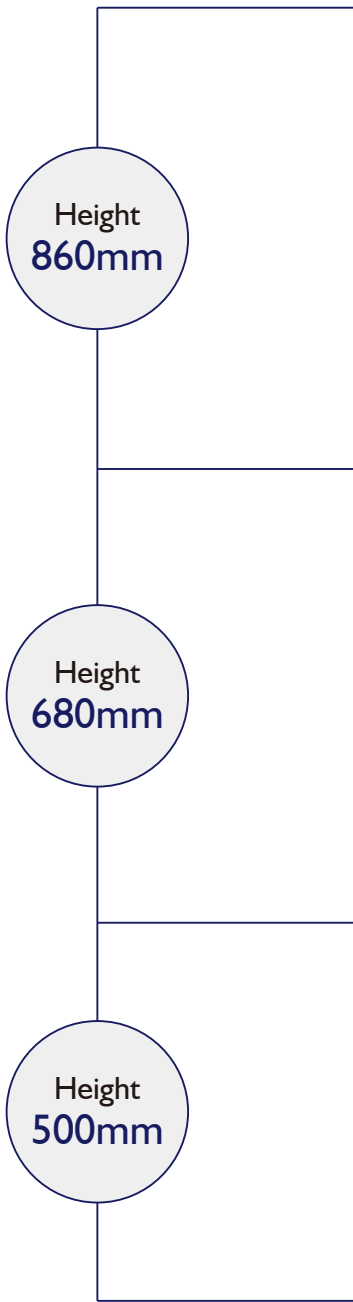

RT865

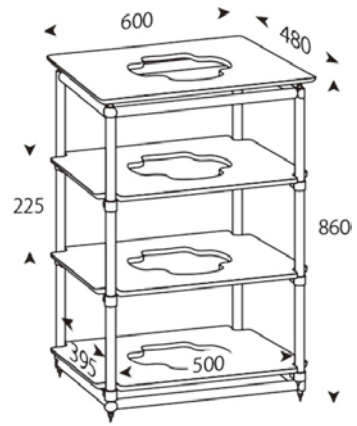

RT864

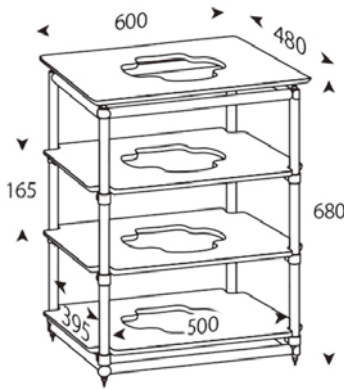

RT684

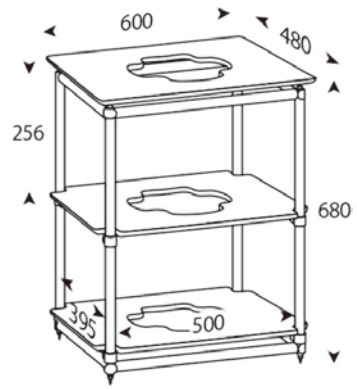

RT683

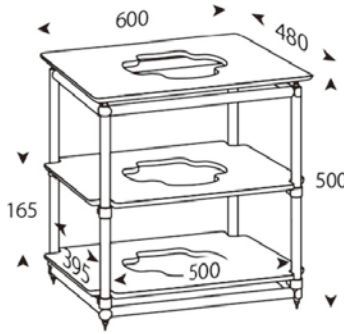

RT503

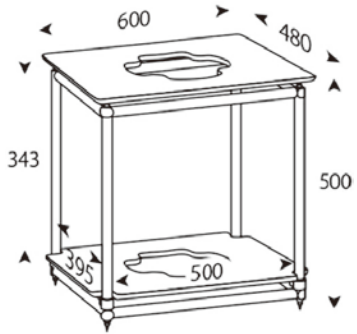

RT502

Rigid Table (Page 10)

- Withstand load per board (when extra thick plate is used)
 - Equipment with 4 feet : 50kg (80kg)
 - Equipment with 3 feet / Multiple units : 40kg (70kg)
- See page 38 for extra-thick board

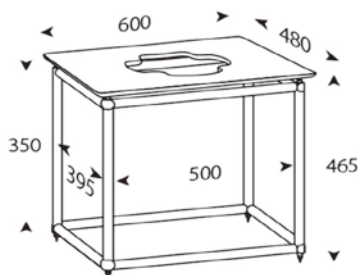
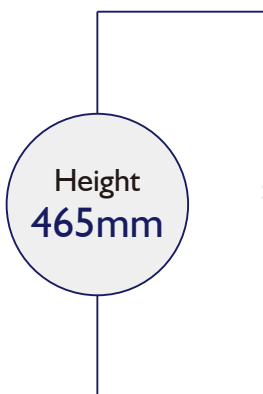

ALT600

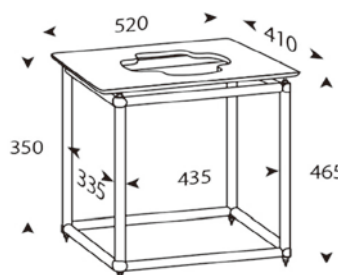

ALT520

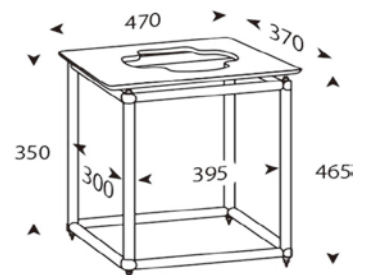

ALT12

Rigid Tower Mid (Page 10)

• The internal width will be -4mm less between the board brackets.

- Load capacity of the entire rack : 250 kg
- Withstand load per board (when extra thick plate is used)
 - Equipment with 4 feet : 50kg (80kg)
 - Equipment with 3 feet / Multiple units : 40kg (70kg)
- See page 38 for extra-thick board

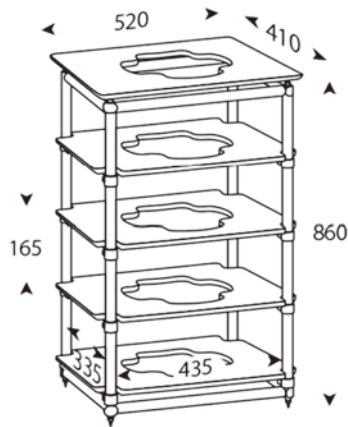
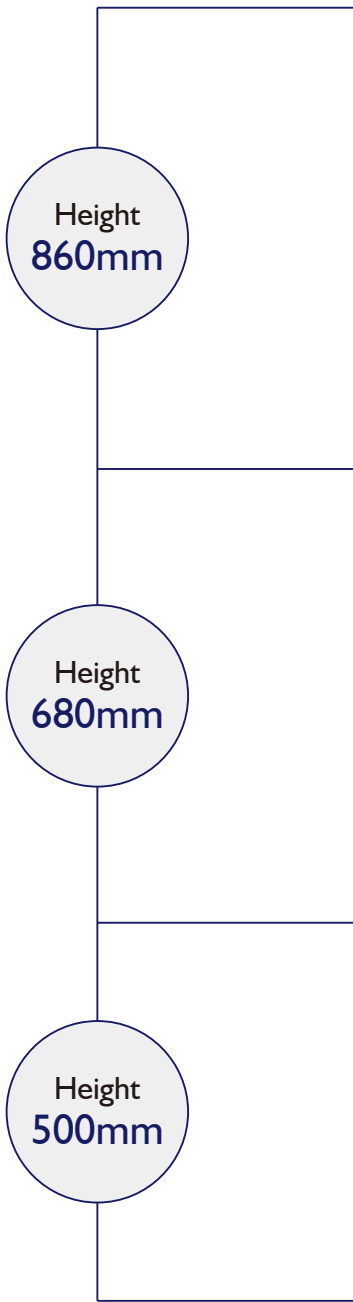

RT865 Mid

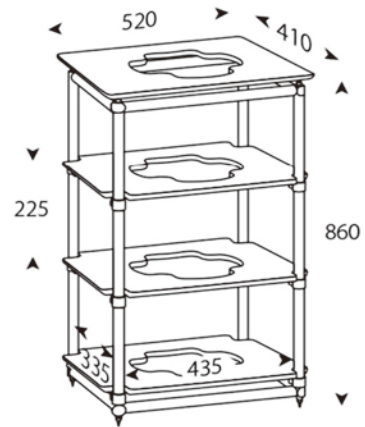

RT864 Mid

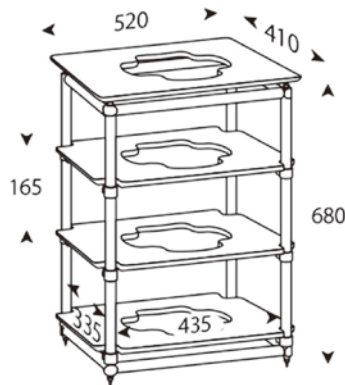

RT684 Mid

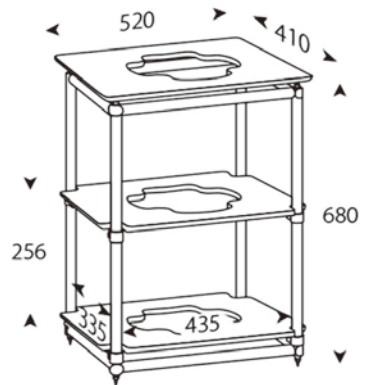

RT683 Mid

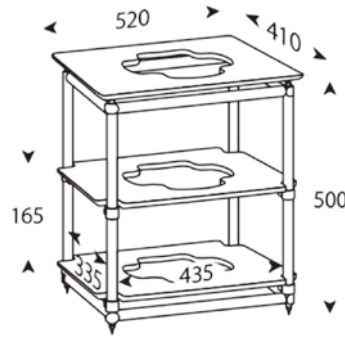

RT503 Mid

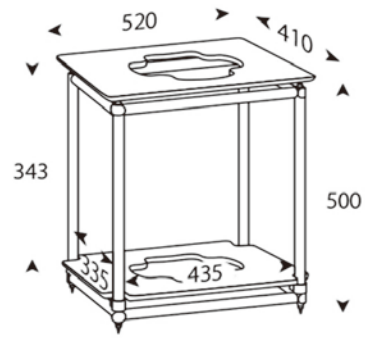

RT502 Mid

Rigid Base (Page 10)

- Withstand load per board (when extra thick plate is used)
 - Equipment with 4 feet : 70kg (120kg)
 - Equipment with 3 feet / Multiple units : 50kg (100kg)
- See page 38 for extra-thick board

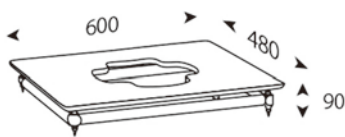
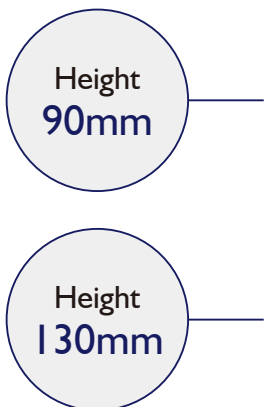

ALB600

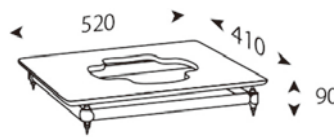

ALB520

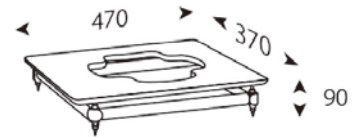

ALB12

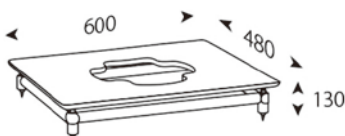

ALB600 / 2

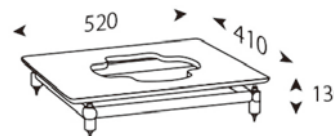

ALB520 / 2

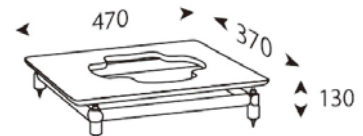

ALB12 / 2

KT Board cutout shape (Grand Series & Rigid Series / Blank board can be also requested)

- The actual product size may have a subtle difference from the values of drawings.
- Regarding the values of others not noted can be asked by request.

KT board cutout shape in gray shows the actual scale for your reference.

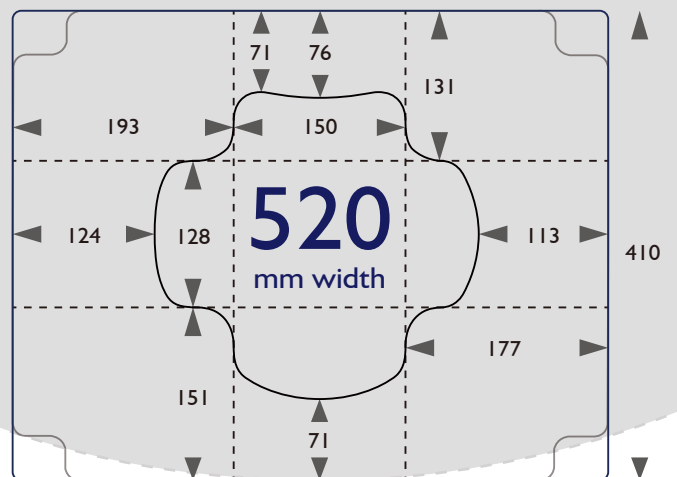
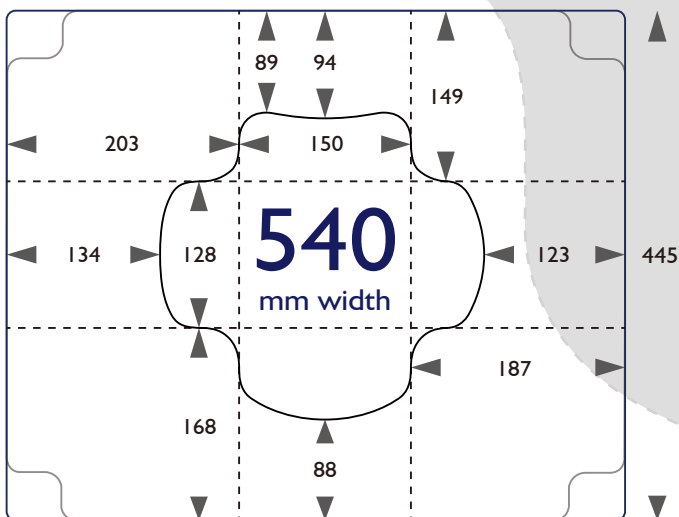
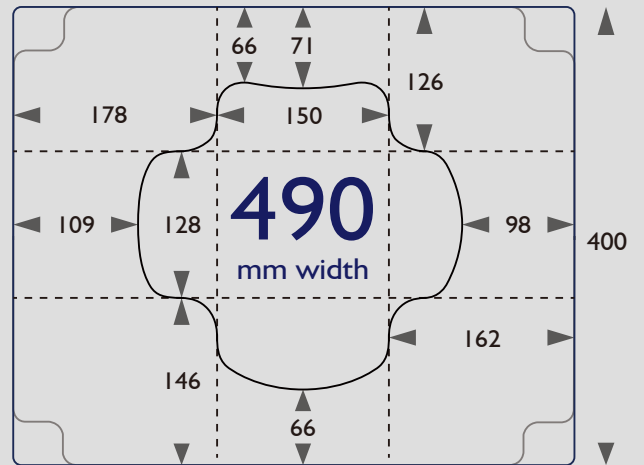
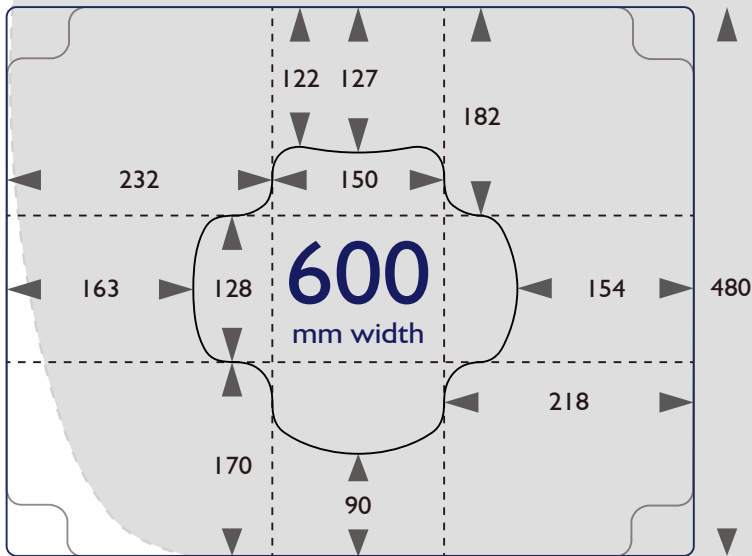
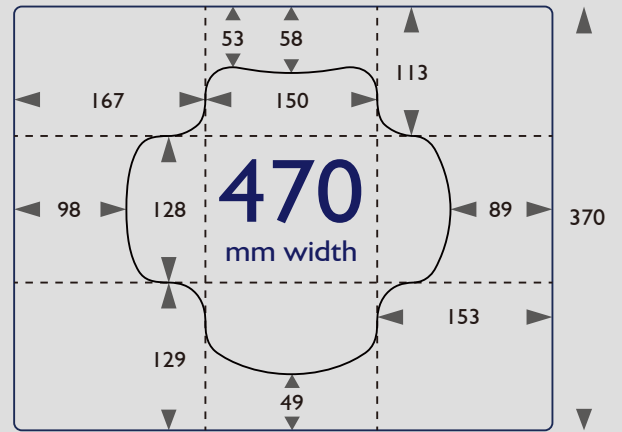
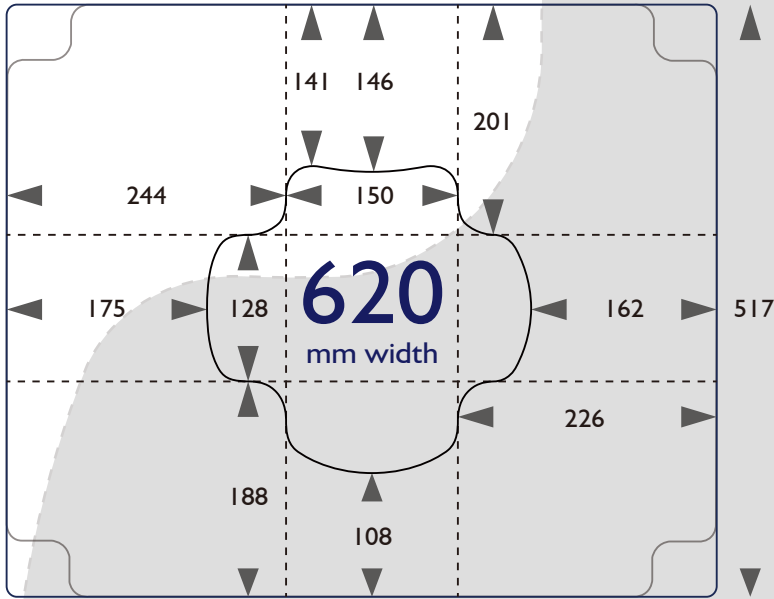

Options (Grand Series & Rigid Series)

● Titanium Top Mounts

Stainless steel made top mounts (Spike receiver of board) come with the rack as standard.

Titanium top mounts (Silent mount technology applied / Page 15) can be replaced to obtain the most possible performance of our racks such as beautiful harmony, stress free, silent atmosphere, clearer musical scale and fullness of base.

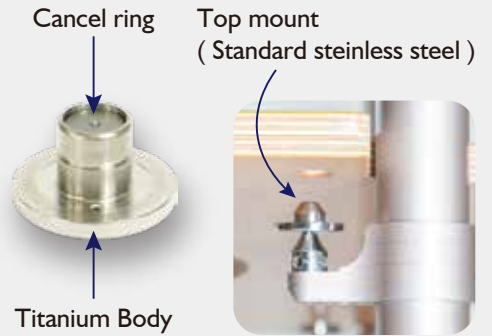

● Long Top Spike

① Long Top Spike 10

② Long Top Spike 20

Lifts up the board by

① 10mm or ② 20mm

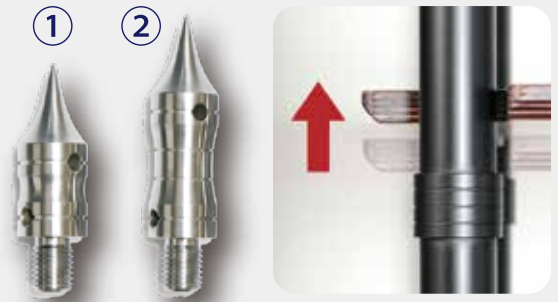

● Solid base attachment for LP12

Use with GS491 • GS492 • GB490 • ALT12 • ALB12 • ALB12 / 2

Linn LP12 original solid base can be placed directly onto the base to perform the utmost performance. Recommended to the true LP12 enthusiast.

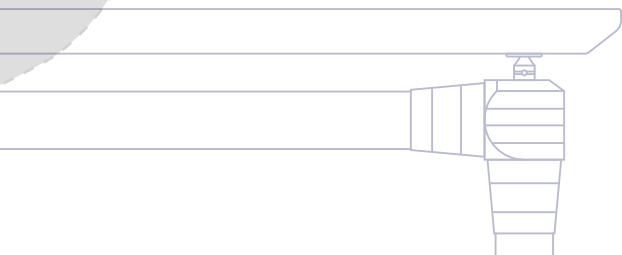

Variations (Grand Series & Rigid Series)

All the racks will be supplied with appropriate numbers of boards, spikes, top mounts and setting tools. Silent mounts are sold separately.

● Colors

Boards can be selected from

- Natural
- Brown
- Black

Frame can be selected from

- Silver
- Black



Natural
×
Silver



Brown
×
Silver



Black
×
Silver

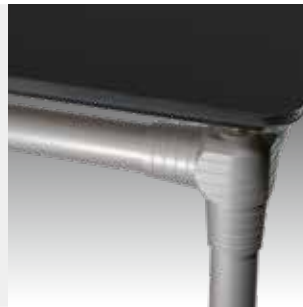

Natural
×
Black



Brown
×
Black



Black
×
Black



● The thickness of boards

Please also mind the whole load capacity of racks noted in the dimension pages.

With the 17.4mm board, the space upward the above board will be 3mm narrower.

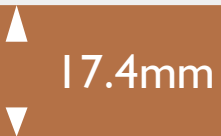

● Shape variations of board

We have several options as below. Please feel free to ask us for more details if you have any questions. KT, KL cutouts and blank boards can be chosen for internal boards as well.



KT type

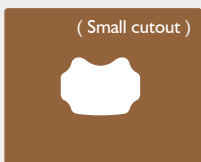

KL type

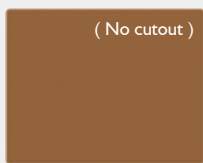

Blank type



S type (for LPI2)



EMT930 type



Garrard 301 type(*)

(* Also 401 / Ortofon & SME tonearm)



Andante Largo Ltd

2-31-16-201, Sakae-cho, Higashimurayama-shi
Tokyo, 189-0013, Japan

<https://www.andante-largo.com/>

info@andante-largo.com

+81-42-393-3412



← Website and Social Media

(260312-1000)